



Little
Athletics
Victoria



2024 Powercor Stawell Gift Little Athletics Events

Dear Athlete

Please be reminded these events will be conducted under Victorian Athletic League (VAL) rules and conditions, therefore it is imperative you make yourself familiar with the rules, conditions, and guidelines within this document prior to your event. The only variation is to the adjustment of handicaps as listed below.

Please note that the Stawell track (Central Park) is a grass track. Running on grass is different from running on an all-weather surface. It could rain and get very soft. Please prepare accordingly.

Ticketing

All tickets must be purchased via Ticketek. Click [HERE](#) to view ticketing information and to purchase tickets.

Athletes will receive a pass as a condition of race entry, which is valid for the entire 3 days; parents will have to purchase tickets.

The athletes can collect their pass from the Stawell Gift Hall of Fame office. Athletes are strongly encouraged to collect their pass on Good Friday.

Timetable

Click [HERE](#) to view the Stawell Athletics Club timetable.

Please note, due to the large number of entrants in the 100mts (both Boys & Girls), Semi-Finals will be conducted in addition to the heats.

Acceptance Rule

Athletes must report to the Stawell Athletic Club (SAC) marquee located on the infield near the circular finish line in front of the SAC pavilion **at least 20 minutes prior** to the event to accept their start. This is the **Acceptance tent**. This is to assist with scratching's and information being placed on the scoreboard during events. **Failure to accept will automatically scratch athletes from the race. They will not be able to take their place at the start line.**

Athletes competing in several events throughout the weekend can accept for the first race and subsequent events at the same time. Please check in early.

Parents will not be able to access the track area except to take athletes to the Acceptance tent.

Handicaps

A full list of events and individual handicaps are available by clicking the link on the LAVic event page [HERE](#).

All Little Athletics races are handicapped by LAVic and are not handicapped in line with Victorian Athletic League, Handicap Regulations.

Handicaps may be altered at the discretion of Little Athletics Victoria; they can be subjected to change prior to and during the event to reflect current performances.

Please note LAVic will be enforcing strict sanctions on athletes who have not provided correct information relevant to their current best performances.

Uniforms

Athletes will be issued with coloured singlets for all Heats, Semis and Finals. Athletes must wear their Centre uniform underneath their coloured singlets (please note; your Commonwealth Bank Registration Patch is not required). The LAVic volunteers will be issuing the coloured singlets to athletes.

Athletes can collect their coloured singlets from the LAVic marquee located at the Southeast end of the ground. The volunteers will have a program and advise the athletes of their colour. **Please report to the LAVic marquee no earlier than 30 minutes prior and no later than 20 minutes prior to your race.**

The singlets must be returned at the conclusion of the race (an LAVic volunteer will be at the finish line to collect these as athletes cross the line).

Please note athletes cannot walk around the inside of the venue without a singlet or t-shirt. Running attire must be worn under VAL rules otherwise a fine and/or penalties may be enforced.

Warming Up

Athletes may warm up on the arena, however when events are being conducted you must sit down if you are in the arena. **This is a VAL rule in which fines and/or penalties may be enforced.**

100m Events

For those athletes wishing to use starting blocks you can bring your own or they will be supplied by LAVic. These will be available at the 100m start.

- **Athletes can place the front block or foot behind the start line where they have been handicapped. So long as this block is on the line it does not matter if your hands are in front of the line.**
- There is a limit of 30m applied to handicaps for the 100m event.
- Number of heats and lane draws will be available in the program, which can be purchased at the event.

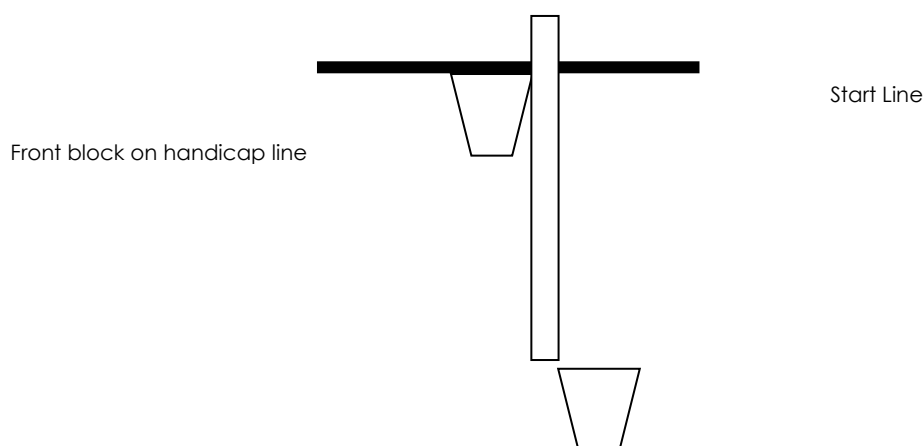

400m Events

These events are un-laned, Boys and Girls compete together in each heat.

- Heats and Final will be a Distance Handicap with a maximum of 100mts.
- Athletes must be well clear before passing and moving to the inside.
- Starting blocks cannot be used.
- Number of heats and lane draws will be available in the program, which can be purchased at the event.

800m Events

These events are un-laned, Boys and Girls compete together in each heat.

- Heats and final will be a Distance Handicap with a maximum of 200mts.
- Athletes must be well clear before passing and moving to the inside.
- Starting blocks cannot be used.
- Number of heats and lane draws will be available in the program, which can be purchased at the event.

1600m Event

This event is un-laned, Boys and Girls compete together in a single final.

- There is a limit of 350m applied to handicaps for the 1600m event.
- You must be well clear before passing and moving to the inside.
- Starting blocks cannot be used.

Progression to Finals

The program will contain information about progressions. Athletes will be advised over the public address system who has made the final and LAVic will have progressions listed on the result board at the LAVic marquee. For any queries, please visit the LAVic marquee for more information. Progressions are as follows:

100mts:

- Heat winners – 11 heats, plus the next 5 fastest times to two Semi-Finals of 8. There will be Semi-Finals for both the Boys 100m and Girls 100m events.
- Semi-Final winners plus next 6 fastest, make up the Final of 8 for Boys & Girls.

400mts:

- First in each heat – 9 heats, plus the next 1 fastest time make up the Final of 10 athletes.

800mts:

- First in each heat – 7 heats, plus the next 3 fastest times make up the Final of 10 athletes.

Note, in an exception to VAL rules and regulations, LAVic reserves the right to alter handicaps at any time, inclusive of between heats, semi-finals and finals. This is a condition of athlete entry.

Starting

Different starting techniques apply in professional running as athletes are spread around the arena on handicaps. The following starting procedures will apply:

100m: "On Your Marks" ..." Set" ... and the gun.

400m to 1600m: Two whistles and the gun. First whistle is "On your Marks", Second whistle is "Set"; then the gun.

A video from last year's event can be viewed [HERE](#) to see the start procedure.

Penalties for Breaking

In VAL running, penalties are applied if an athlete breaks, as follows.

100m	1 metre penalty
400m	1 metre for Heats / 2 metres for Final
800m	1 metre for Heats / 2 metres for Final
1600m	5 metre penalty

Two breaks will be automatic disqualification.

Note: The penalty only applies to the current round, it is not carried forward if the athlete progresses to the next round.

Use of Spikes

- Spikes may be worn by all athletes in all events under VAL rules. There are no size restrictions as to the length of spikes.
- As a guide, athletes should only consider using 7mm or 9mm.
- U9 and U10 athletes are not permitted to use spikes in normal LAVic events. They are allowed in VAL events only, however it is not recommended.

Crouch Starts

- Crouch starts are permitted, but are not mandatory, in all events.

3 Point Starts

- 3 point starts, where one hand touches the ground forward of the line, yet your feet are behind the line is permitted in circular events in VAL races only.
- This is not permitted in normal LAVic events.
- This is an alternate to the crouch or standing start.
- A video explaining how to do a 3 point start can be viewed [HERE](#).

Lining up for your Race

- In sprint events athletes will line up at the end of the track in a line whilst the starter tells the field the instructions. Athletes will then be told to walk to their marks or handicaps.
- In the Heats of the 400mts and 800mts, all athletes will line up at the start line, whilst the starters and LAVic volunteers provide the instructions.
- In the Final of the 400mts, 800mts and 1600mts circular events all athletes will be whistled to line up at the backmarkers handicap. This means the spot where the athlete with the lowest handicap is starting. You will be given instructions by the starter then told to walk to your marks or handicaps.

SAC and LAVic volunteers will be on hand to assist the athletes to find their mark.

Presentations

- If an athlete wins a Final, they will be required to attend the presentation dais to be presented with their sash immediately following the race. Only the winner receives a sash, there are no medals for 2nd/3rd etc.

Access to the Arena

- Only athletes and LAVic Volunteers will be granted access to the arena.

Photographs

Photographs will be taken by the LAVic official photographer, they will be available on the LAVic Facebook page.

During this event there will be athletes participating who are unable to be photographed, please ensure that you are only photographing and/or sharing images of your own children and or those where they have parental permission. The safety of children is paramount, and we appreciate you respecting and understanding this request.